

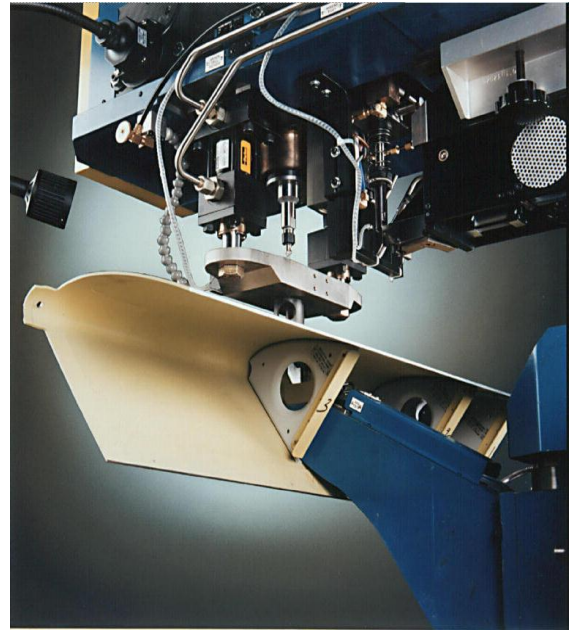

ELECTROIMPACT, INC.

Corporate Headquarters
4413 CHENNAULT BEACH ROAD
MUKILTEO WA 98275
PH: (425) 348-8090 ● FAX (425) 348-0716
Visit Us ON the Web: www.electroimpact.com

Model – EI-LE-08-48-DK (DUAL KNEE)

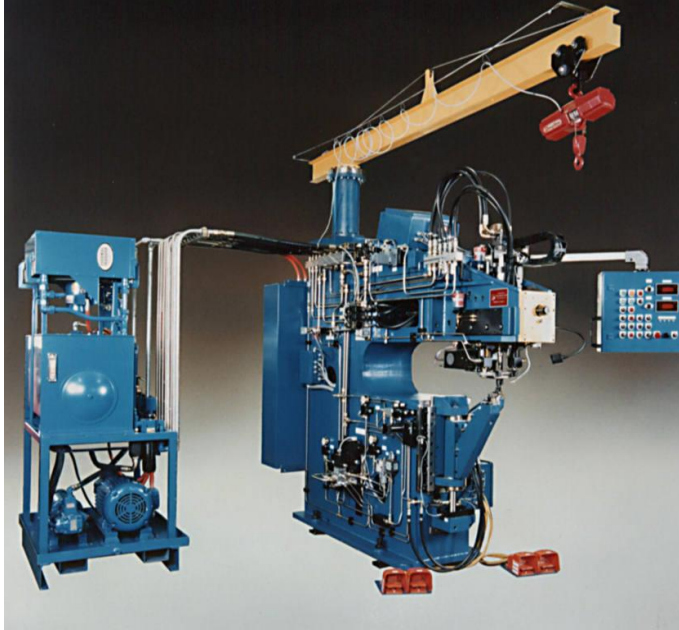

The Leading Edge Dual Ram (Knee) style automatic fastening machine, is supplied with two lower rams, each sized, and configured to allow for primary fastening of flanges inside the leading edge of the wing section. This allows for processing of close clearance parts, ducts and can be used on standard flat assemblies for rivet installation.

The lower ram allows for access for various parts that a standard lower ram may not be able to reach. This is the advantage over conventional lower ram configurations.

The lower ram consists of rotational tools that can be rotated 90 degrees to allow for access on each side of the stringer in most aircraft parts. The ram provides 4 (four) working positions and easy access to fasteners located in corners of the production parts.

The machine can be supplied with either a Mini-Hopper Feed System or a Vibratory / Hopper Automatic Feed System.

Machine upset is hydraulically actuated and applies upset forces up to 8,000 pounds for installation of fasteners up to 3/16 inch. The upper head consists of a

highly reliable toggle link transfer with
the capability of supplying all your
fastening needs.



System Description

Model # EI-LE-08-48-DK (LE= Leading Edge, DK=Dual Knee)

Standard

- ▲ Programmable Logic Controller
- ▲ Upset Force 8,000 Pounds
- ▲ XX Inch Throat Depths 48" inches (1219.2mm)
- ▲ Capable of Drilling Aluminum, Steel, and Titanium Alloys
- ▲ Maximum Cycle Time Clamp to unclamp 3.5 sec. (without shave and sealant cycles)
- ▲ Machine Cycle Counter
- ▲ Set Up, Tool Change, and Run Modes
- ▲ Missing Rivet and Broken Drill Detector
- ▲ Chip Blowers
- ▲ Horn Position Sensors
- ▲ Clamp Safety Switch
- ▲ Work Height Switch
- ▲ Drill Spindle to Accept Acura Flex Collets
- ▲ Capable of Installing Universal, Flush Head, and Modified Universal Head Rivets.
- ▲ Countersink Adjustment Range 0 to .50 Inches
- ▲ Drill Speed Adjustable from 500 to 7000 RPM
- ▲ Variable Drill Feed Adjustable from 2 to 96 IPM
- ▲ Adjustable Clamp Force from 0 to 750 Pounds
- ▲ Countersink Selection in 0.0005 Increments
- ▲ Maximum Stack Thickness .500 Inches
- ▲ Work Height Approximately 49 Inches (1244.6mm)
- ▲ Mini Hopper feed system

Optional

- ▲ 7-1/4 Inch Deep Drop/Daylight Opening (5-inch standard)
- ▲ 2-1/2 Deep Pocket
- ▲ Automatic Grip Sensing
- ▲ Laser Spot Locator
- ▲ Vibratory Bowl AFS Capable of Expanding to 20 Bowls
- ▲ Retractable and Resilient Pressure Foot Bushing
- ▲ Manual Drop Station
- ▲ Upper and Lower camera system
- ▲ Smart Panel Display with Diagnostics

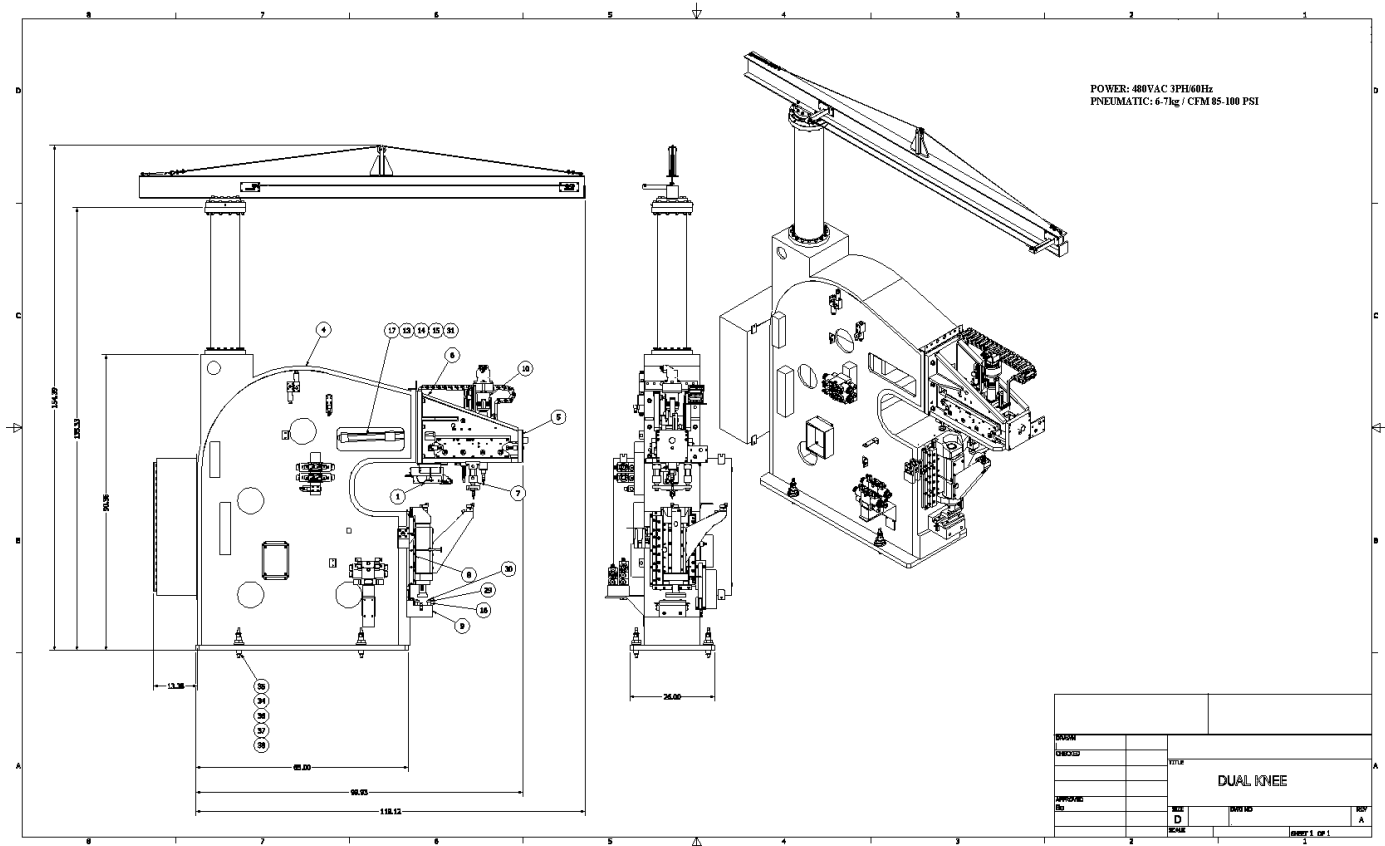

ELECTROIMPACT, INC.
 WA. 98275
 C-FRAME RIVETER DIVISION
 425.348.8090

4413 CHENNAULT BEACH RD. MUKILTEO,

PH: